

A COUPLER FOR THERMOGRAVIMETRY-GAS CHROMATOGRAPHY*

JEN CHIU

Plastics Department, E. I. du Pont de Nemours & Company, Du Pont Experimental Station, Wilmington, Delaware 19898 (U. S. A.)

(Received November 17th, 1969)

ABSTRACT

A technique coupling thermogravimetry (TG) and gas chromatography (GC) has been previously described [*Anal. Chem.*, 40 (1968) 1516], which separates and analyzes the volatiles generated at various weight-change stages as shown on the TG curve. Applications of such a technique for studying polymer blends and copolymers, analyzing organic coatings, and identifying solvents, monomers and additives in polymer systems have been demonstrated. The present work describes the construction and operation of an all-metal coupler to replace the glass coupling system previously used. The apparatus is semi-automatic, easy to operate, and readily built from standard components. It can be adapted to most commercial TG and GC instruments without much modification. Examples are given to illustrate the performance of this unit.

INTRODUCTION

Coupled thermogravimetry-gas chromatography (TG-GC) has been shown to be a valuable technique for materials characterization¹. It provides a profile of weight changes of a substance being heated under controlled conditions, and analyzes the volatiles generated at various weight-change stages. Both qualitative and quantitative information can be obtained from the TG and GC scans. The technique is particularly useful in analysis of mixtures having components of differing volatilities, study of decomposition mechanisms, determination of trace amounts of impurities, and characterization of molecular structures. The advantages and limitations of such a coupled system were discussed previously, together with some practical applications to polymer systems.

In the previous work, the coupling unit was a borosilicate glass structure consisting of four glass stopcocks. This paper describes a semi-automatic all-metal coupler which is easy to operate and readily built from standard commercial components. It can be easily adapted to most commercial TG and GC instruments without much modification. Examples are given to illustrate applicability of this unit.

EXPERIMENTAL

The basic design of the present coupler is essentially the same as the glass unit

*Presented at the Recent Advances in Thermal Analysis Symposium, American Chemical Society Meeting, Houston, Texas, U. S. A., February 22-27, 1970.

previously described¹, except that the four switching stopcocks are now replaced by four stainless steel micro-volume valves (Cat. No. 2011, Carle Instruments, Inc., Anaheim, California, U. S. A.), and the switching operation is performed by solenoid valves. This semi-automatic feature paves the way for further automation and programming of the whole operation.

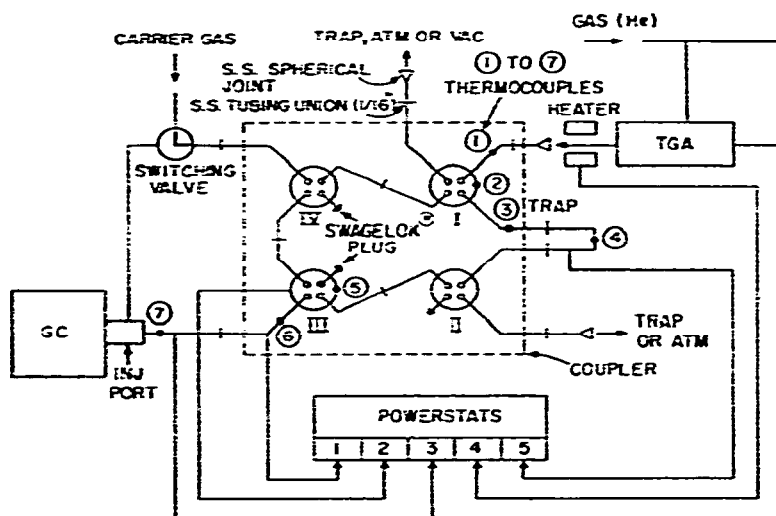

Fig. 1. Schematic diagram of TG-GC coupler.

The connection of these micro-valves and the coupling of this unit to TG and GC is shown schematically in Fig. 1. The micro-valves and all necessary plumbing and heating are contained in a steel box (17 × 9 1/2 × 11 in) as indicated by the dashed line. In this unit, the coupler is connected to the Du Pont 950 Thermogravimetric Analyzer module of the Du Pont 900 Thermal Analysis System (Instrument Products and Equipment Division, E. I. du Pont de Nemours & Co., Wilmington, Delaware, U. S. A.) and a F & M 810 Research Gas Chromatograph (Hewlett Packard Co., Avondale, Pa., U. S. A.). "Swagelok" fittings are used for connections with the 1/16-in stainless steel tubing attached to the micro-valves. The sample trap is also made from a convenient length of 1/16-in tubing shaped in either coil- or U-form. The valve design is based on a kinematic loading principle to achieve leak-tight operation at temperatures up to 250°C and pressures up to 100 psi. The two-position valves can be operated either manually through a knob or automatically through a compressed air actuator (Cat. No. 2050, Carle Instruments, Inc.). By use of a miniature air cylinder and a two-way AC solenoid valve, the actuator applies laboratory air pressure to switch the valve by driving a crankarm between precision stops.

The valves are heated by flexible heating tapes (110 V, 3 Amp., Cat. No. HT-302, Electrothermal Engineering Ltd., London, Great Britain). All tubing connections are heated by "Glassohm" resistance heaters (110 V, 22 Ω, 5 Amp., Clarostat Mfg. Co., Dover, New Hampshire, U. S. A.). Five powerstats are used to control the temperatures of the various parts of the system: TG furnace tube end, sample trap, micro-valves, injection line to GC, and connection tubings inside the coupler. Seven

thermocouples are located at strategic points, namely, between TG connector and valve I, between valve I and sample trap, sample trap, valve III, between valve III and exit of coupler, and between exit of coupler and GC injection port. These points are marked on the diagram in Fig. 1. The temperature at each point is read from a potentiometer through a selector mounted on top of the coupler.

A switching valve is installed to switch the carrier gas either to the coupler for TG-GC operation or to GC directly for normal GC operation. An additional purge gas inlet is added at the end of the cold envelope of the Du Pont TGA unit to sweep out the pyrolysis products more completely. When the coupler is in standby position, the TG furnace can be either disconnected from the coupler or vented to the atmosphere or a trap through valve I. This position also can be used to evacuate the TG unit to achieve vacuum or inert atmosphere. If liquid nitrogen is used for trapping the volatiles, it is desirable to attach at least one similar trap to valve II to protect condensation of atmospheric gases in the sample trap.

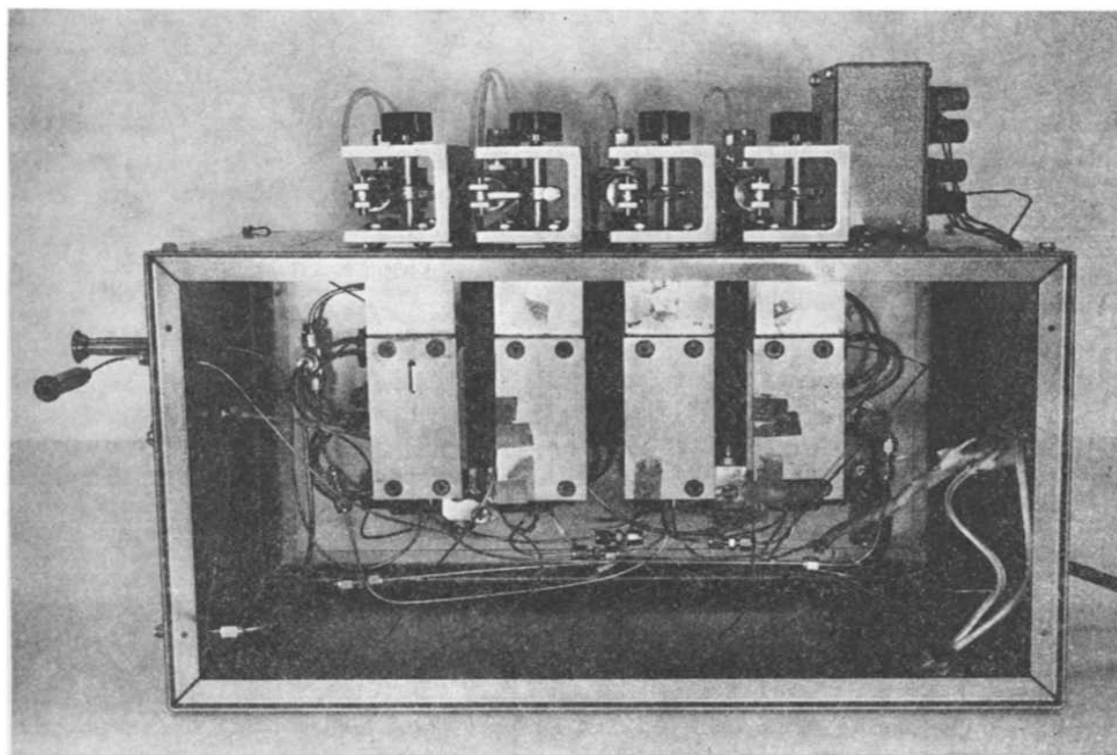

Fig. 2. Rear view of the opened TG-GC coupler.

The valves are arranged in a row in the rear part of the coupler as shown in Fig. 2. The actuators are mounted on top of the coupler and insulated from the hot box. The solenoid valves are housed in the front of the coupler and insulated from the hot oven compartment as shown in Fig. 3. The completely assembled unit in coupled position is shown in Fig. 4. A small dewar is used for trapping, and a small heating

mantle (Glas-Col Apparatus Co., Terre Haute, Indiana, U. S. A.) for volatilization of the sample.

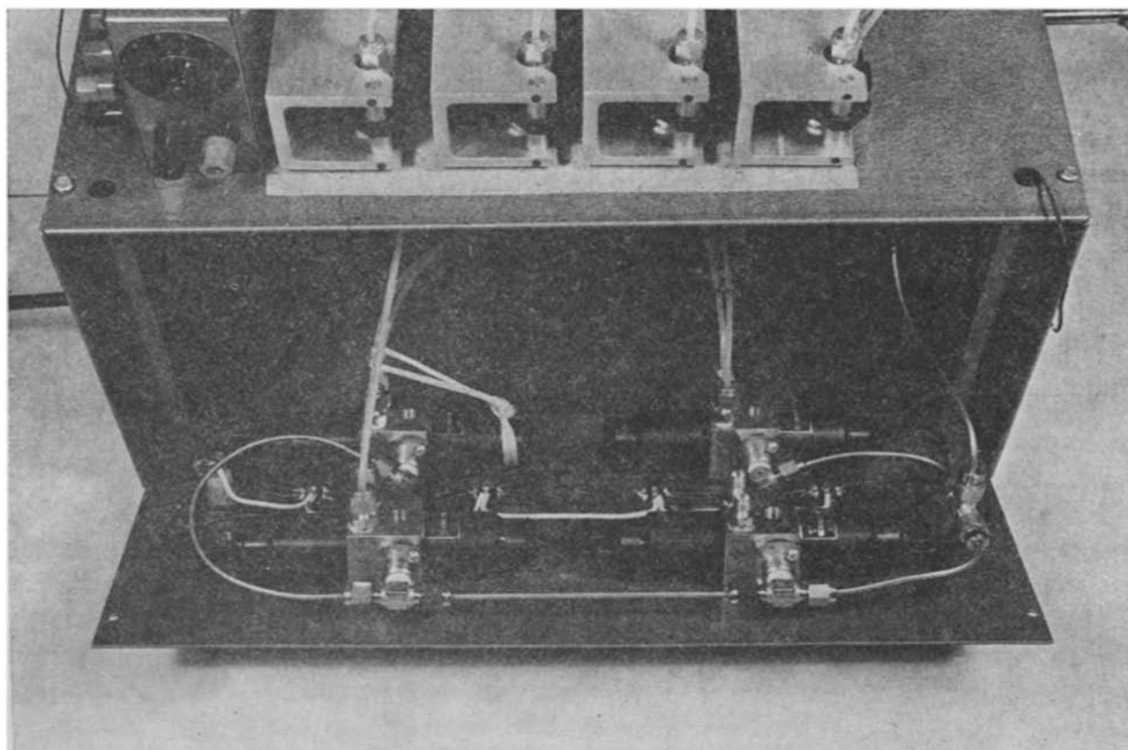

Fig. 3. Front view of the opened TG-GC coupler.

Each micro-valve has two positions and its flow geometry is shown in Fig. 5. The positions of the four valves during the various operations are best summarized in Table I. However, a certain order of switching the four valves is preferred. The following sequence is recommended for highest column efficiency, particularly for the injection step.

TABLE I

VALVE POSITIONS

<i>Valve No.</i>	<i>Standby</i>	<i>Trapping</i>	<i>Volatilization</i>	<i>Injection</i>
I	A	B	A	A
II	A	B	A	A
III	B	B	B	A
IV	B	B	B	A

Standby: IV-B, III-B, II-A, I-A; trapping: I-B, II-B, III-B, IV-B; volatilization: I-A, II-A, III-B, IV-B, trap heater on; injection: IV-A, I-A, II-A, III-A, trap heater off.

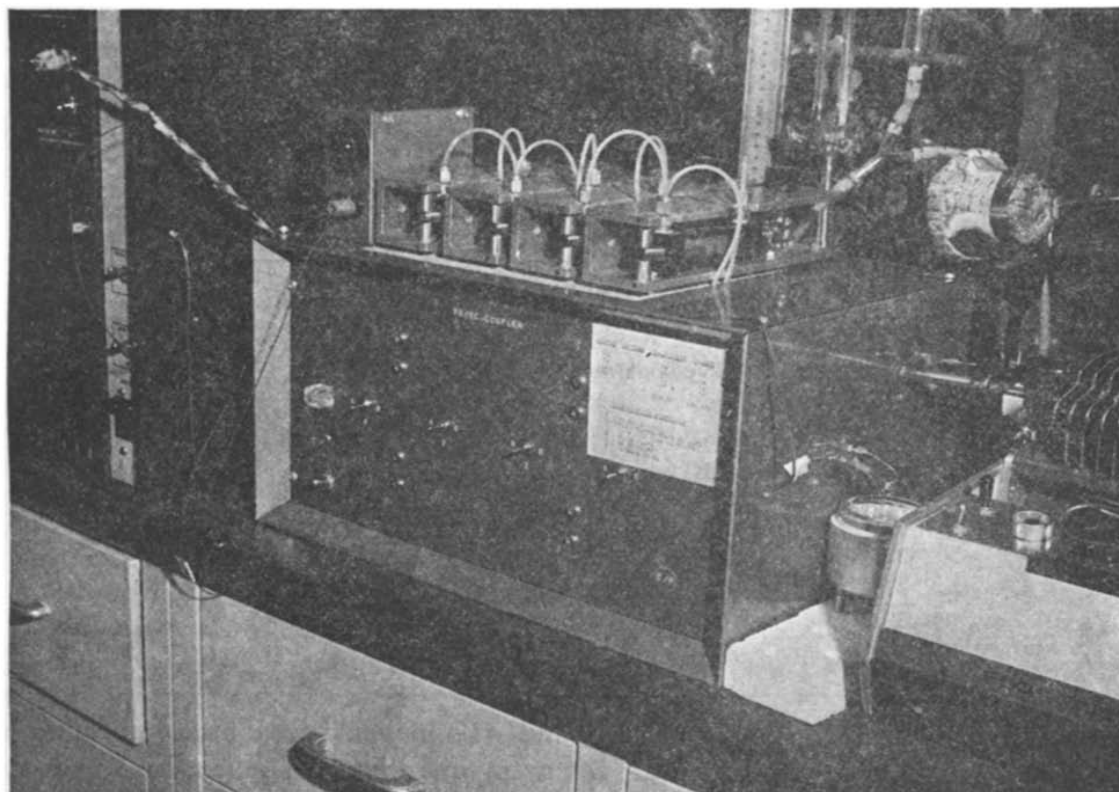

Fig. 4. TG-GC coupler in assembled position.

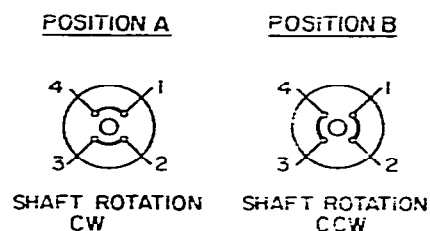

Fig. 5. Flow geometry of micro-valves in TG-GC coupler.

RESULTS AND DISCUSSIONS

Polymethyl methacrylate

The precision of the total system was tested by decomposing approximately 1 mg of a polymethyl methacrylate sample, free of monomer and other additives, in the TG furnace maintained at 400°C. The monomer was separated on a stainless steel packed column, 6 feet long \times 1/8 in diameter, containing acid-washed Chromosorb W (80-100 mesh), coated with 10% silicone rubber UC W-98 (Hewlett Packard Co.). The column was maintained at a constant temperature of 60°C. Helium served as the carrier gas with a flow rate of 30 ml per minute at an inlet pressure of 100 psig.

The injection port temperature was 200°C; detector block temperature, 250°C. A dual hydrogen flame detector was used. Retention times and peak areas were read from an electronic digital integrator Model CRS 100 (Infotronics Corporation, Houston, Texas, U. S. A.). The results for six consecutive runs are shown in Table II.

TABLE II
TG-GC OF POLYMETHYL METHACRYLATE

Run No.	<i>Monomer methyl methacrylate</i>		
	<i>Retention (min)</i>	<i>Area (10³ counts/mg)</i>	<i>Height (in/mg)</i>
1	2.8	17.3	6.64
2	2.6	17.1	6.58
3	2.8	18.8	6.72
4	2.8	17.2	6.96
5	2.9	18.5	6.78
6	2.9	17.7	6.79
	Average 2.8	17.8	6.75
	Standard dev. 0.1	0.7	0.13

Reproducibility of 2% in peak height and 4% in peak area measurements was obtained. This is more than adequate for many quantitative applications. However, a 30% reduction in column efficiency is normally observed.

Battery separator

One of the important applications of a coupled TG-GC technique is to characterize polymer materials by analysis of their pyrolysis products. In this capacity, coupled TG-GC is equivalent to controlled pyrolysis-GC plus weight loss. Painstaking searching for pyrolysis conditions is normally not necessary. This is illustrated by a practical example of using coupled TG-GC in conjunction with infrared (IR) and differential thermal analysis (DTA) for identification of a battery separator. IR analysis indicates the material to be made of polyamides. DTA shows melting endotherms in the regions of 215 and 255°C, which suggest a mixture of nylon 6 or 610 and nylon 66. Coupled TG-GC analysis then identifies the material to be a mixture of nylon 6 and nylon 66. The TG-GC scans are shown in Fig. 6 for the battery separator and three control nylons. The TG scans show that the separator decomposes at a much lower temperature than the control nylons because of the presence of strongly caustic substances, a fact likely to be overlooked by conventional pyrolysis-GC. The residual weight provides information on inorganic materials in the sample. The decomposition products of the separator are shown as bar graphs in the pyrograms and compared with those from the control nylons. The separator produces predominantly caprolactam and cyclopentanone, which are the main decomposition products from nylon 6 and nylon 66, respectively.

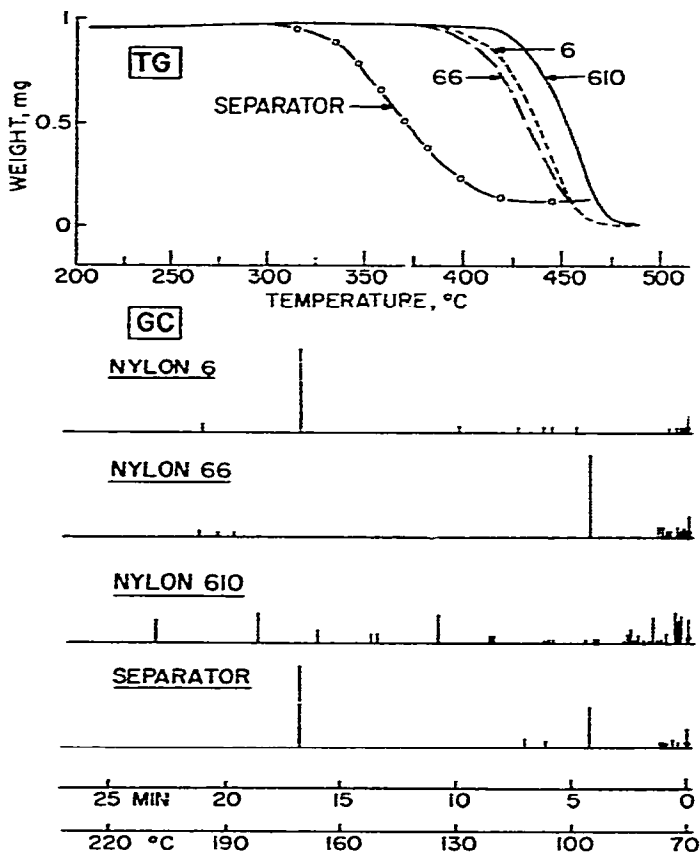

Fig. 6. TG-GC of battery separator. (TG conditions: sample size, ~ 1 mg; helium flow, 160 ml/min; heating rate, $10^\circ/\text{min}$).

The GC conditions are the same as those for polymethyl methacrylate described in the preceding section except that the column temperature is programmed at a rate of 6° per min from 70 to 220°C.

Aerosol spray

Stepwise analysis of the volatiles generated at various weight loss steps shown on the TG curve frequently provides both qualitative identification and quantitative determination of the constituents involved. For instance, coupled TG-GC has been employed in an attempt to identify the polymer components in an aerosol spray. After the solvents and propellants are evaporated and identified by direct GC and IR analyses, the dried solid residue is studied by coupled TG-GC. The GC conditions are the same as before except the columns are maintained at 38°C. As shown in the TG scan in Fig. 7, the sample shows 2% residual solvents, 2% ash, and two major weight-loss stages involving 44% and 52% in the temperature regions of 200–420 and 440–580°C, respectively. During the continuous heating process, a sample is taken at each major weight loss step as indicated on the TG curve, collected in the coupler,

and then analyzed by GC. The GC scans, shown as bar graphs in Fig. 7, identify sample 1 as mainly methyl methacrylate and sample 2 as mainly tetrafluoroethylene.

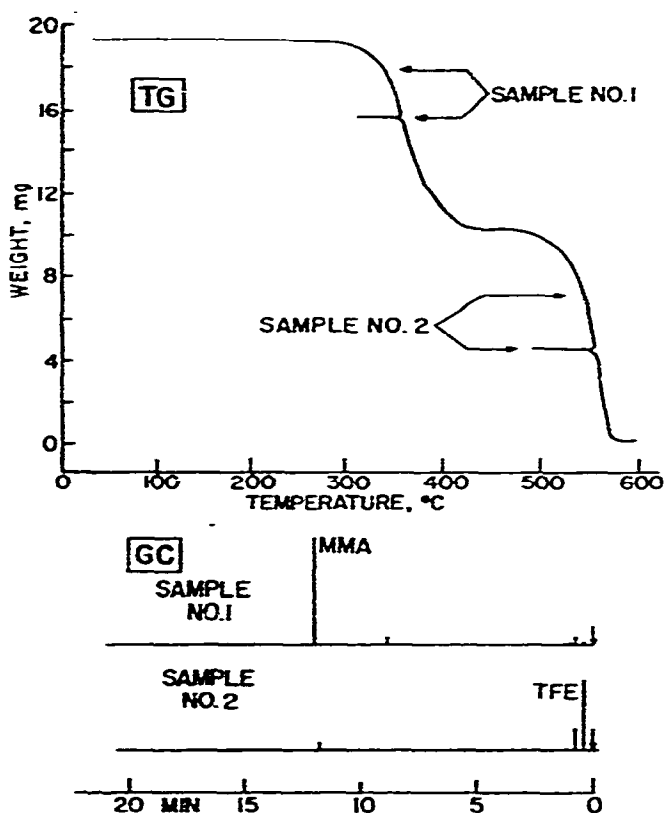

Fig. 7. TG-GC of aerosol spray. (TG conditions: sample size, ~ 20 mg; helium flow, 160 ml/min; heating rate, $5^\circ/\text{min}$).

The results suggest that the solids in the spray contain mainly polymethyl methacrylate and polytetrafluoroethylene. It is noted that the two major weight-loss steps are consistent with the thermal decomposition regions of the two polymers. However, TG alone does not provide absolute identification. Other analyses such as DTA and IR support the TG-GC results.

REFERENCE

- 1 J. CHIU, *Anal. Chem.*, 40 (1968) 1516.